

## I DDE/OPC communication with S5 PLC's

### What do you need?

#### a) Production site:

- echolink package with RS 232C / 20mA converter cable
- network adapter (Twisted Pair)

#### b) Visualization PC:

- ethernet adapter
- H1 or TCP/IP bus-interface with fetch/write functionality

Several possibilities are available, such as

- existing CP1413 interface
- INAT DDE-Server (for Intouch, Excel, Visual Basic...)
- INAT OPC-Server (for WinCC, FactoryLink, FIX, RSView...)
- You may also fetch data out of the PLC via echolink with every TCP/IP stack (e.g. from UNIX). You just have to imitate the S5AP header. You have free access to this header. Moreover it is well documented and very easy to implement.

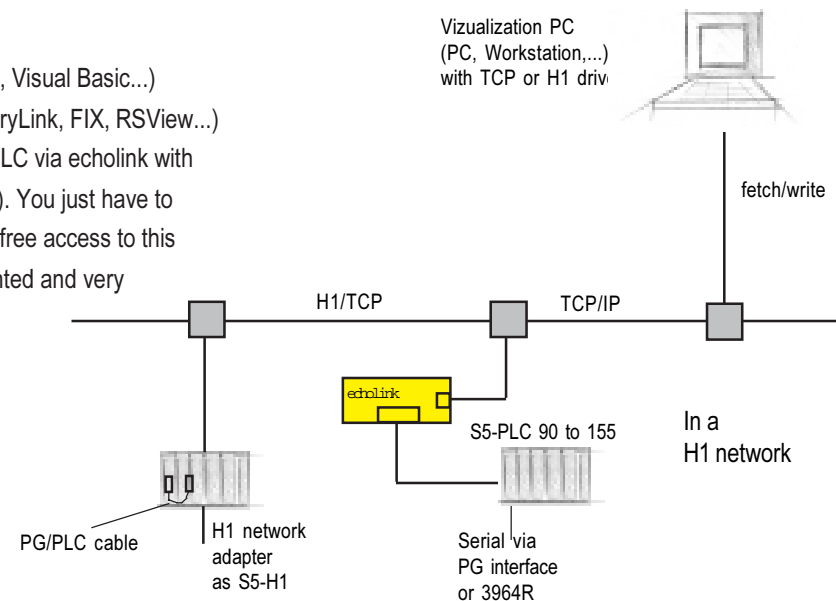

### How it works:

#### a) Production site:

- Connect the S5 PLC and the echolink with the PG converter cable in the package.
- Connect the echolink via network interface (TP) to your LAN.
- Assign the echolink an unambiguous Ethernet address and IP address respectively. This has to be done with the parameterization software in the package.
- Parameterize a fetch/write connection on the echolink by defining the TSAP's and ports respectively.

#### b) Visualization PC:

- Connect your workstation to the network.
- Indicate the Ethernet address and IP address respectively of the destination of the echolink (e.g. DDE server or OPC server).
- Specify the TSAP and the port respectively with which you want to communicate.
- Define the items you want to fetch/write out of the S5 PLC (DDE or S5 AP definition) e.g. with excel via DDE:= \* |echolink!DB5DW0

Now you are able to access to all typical data areas of the SPS, e.g. data blocks, flags, input bytes, output bytes

## II Remote Maintenance with PG or PC and any S5 Software

### What do you need?

#### a) Production site:

- echolink package with RS 232C / 20mA converter cable
- network adapter (Twisted Pair)

#### b) Remote office:

- PC or PG with serial interface
- Any S5 programming software with option "bus selection"
- echolink
- network adapter (Twisted Pair)

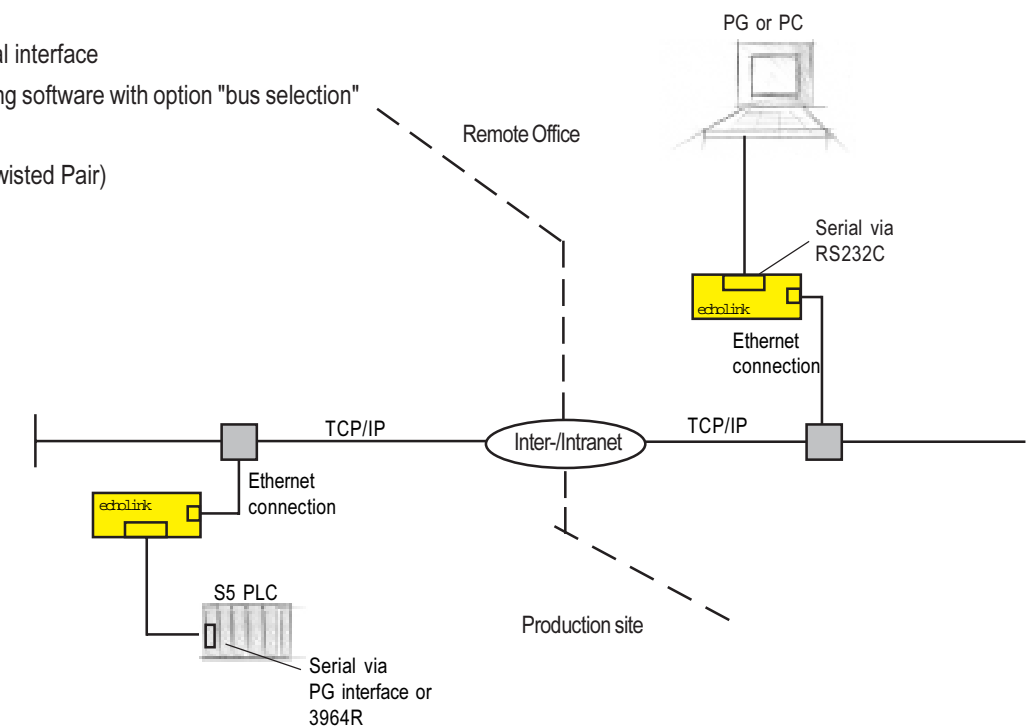

### How it works:

#### a) Production site:

- Connect the S5 PLC and the echolink with the PG converter cable in the package.
- Connect the echolink via network interface (TP) to your LAN.
- echolink has an unambiguous IP address and is - with the connection to the LAN - reachable via internet.
- Parameterize a fetch/write connection in the echolink.

#### b) Remote office:

- Connect your PC or PG to the echolink (serial).
- Start your "S5 programming software".
- Establish the connection with the option "bus selection" (connection via TCP/IP and set up of the net).
- Select the destination: echolink at the production site.

Now the connection is established. You are able to access to the PG interface of the SPS at your customers.

**NB!** If the S5 is equipped with the S5-TCP/IP or a corresponding communication processor, an echolink on production site near the PLC is not necessary. In this case the PLC already has an unambiguous IP address. Plug in the PG/PLC cable and the PLC is connected with the remote office without echolink.

### III Data conversion serial to Ethernet (Telnet Functionality)

**Background:**

All signs/data getting over the serial interface into the echolink within 5ms, will be converted to an ethernet protocol. On the opposite site the ethernet protocol will be converted back to the signs/data of the beginnig. In this way a transparent transport of the data is possible.

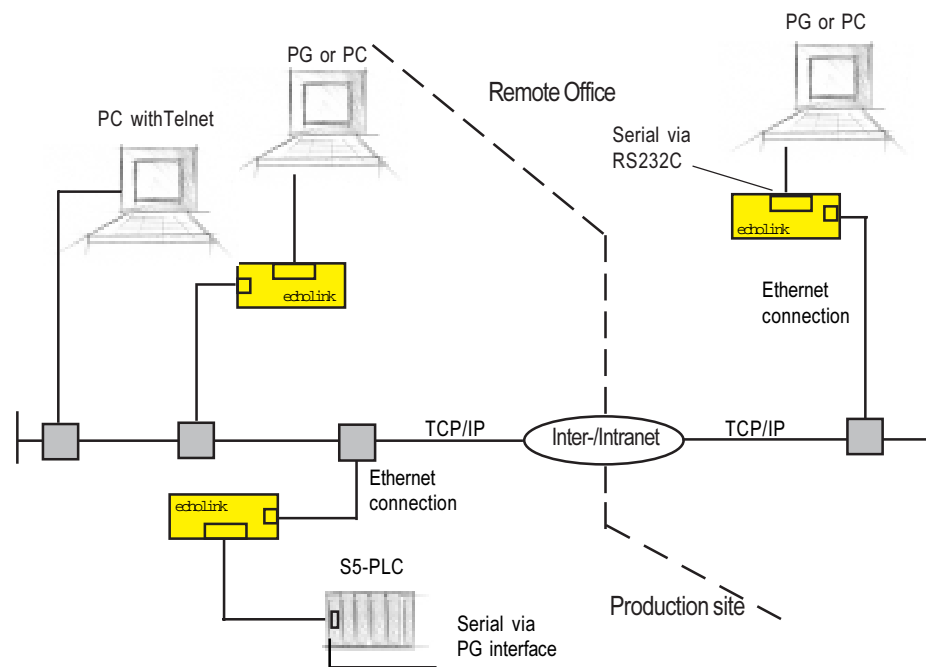

**What do you need?**

- a) Local production site:
    - echolink package with RS 232C / 20mA converter cable
    - network adapter (Twisted Pair)
  - b) Visualization PC:
    - echolink-package
    - your application software
    - serial cable to connect echolink with the PC
- or:
- ethernet adapter
  - application with telnet funcionality

**How it works:**

- a) Production site
    - Connect the PLC and the echolink with the PG cable in the package.
    - Connect the echolink via network interface (TP) to your LAN.
    - Assign the echolink an unambiguous Ethernetaddress and IP address respectively. This has to be done with the parameterization software in the package.
    - Parameterize a telnet-connection on the echolink, by defining the destination address or the portnumber.
  - b)
    - Connect your PC to the echolink (serial).
    - Assign the echolink an unambiguous Ethernetaddress and IP address respectively. This has to be done with the parameterization software in the package.
    - Parameterize a telnet-connection on the echolink, by defining the destination address or the portnumber.
    - Start your application: Use the serial interface connected with the echolink
- or:
- Connect your workstation to the network
  - Start your application, that supports telnet

All data sent via serial interface, can now be sent and received 1 to 1

NEW Free Entree to the Industrial Ethernet

### INAT echolink: Technical Data

INAT echolink is the intelligent Ethernet adapter for PLCs and programming devices (PGs). With INAT echolink, PLCs without any network adapter like the S5-90, S5-95 and S5-100 are able to communicate via network and are equipped for the remote maintenance via internet. Especially after bringing plants into service many expensive local service commitments are necessary, which can be reduced with the remote access to a plant. Up to now for remote access local stations and remote PGs (PCs) were connected by two modems and a long distance call. With the INAT echolink you perform remote maintenance via internet, which means with a cheap local phone call. Simply select the IP address of the station (or the Domain Name) in the Internet. Now you are able to program your PLC and monitor the state of your PLC from a remote host.

- Supply voltage**  
24 V DC
- Current Consumption**  
300 mA
- Permitted ambient conditions**  
0...55°C
- Degree of protection**  
IP20
- Interfaces**  
Twisted Pair (TP) for ethernet connection  
up to 5 x RS 232C
- Measures [mm]**  
174 x 300 x 56